

# Capiphon™ Drainage Installation Guidelines

## General Drainage

There are two<sup>s</sup> main ways in which to install Capiphon™ for general drainage: laid horizontally or laid vertically.

### 1. With the Capiphon™ belt laid flat

- Depending on the drainage challenge, and the soil type, dig a number of shallow trenches 1-5 metres apart, and up to 10 metres long, across the area in a herring bone pattern. In general
  - The higher the clay content the closer the spacing,
  - The higher the risk of damage or inconvenience caused by flooding, the closer the spacing,
  - The higher the rainfall – volume and intensity, the closer the spacing.
- Dig these trenches down below the cultivation depth, but they need not be as deep as conventional drainage trenches. 2-7 cm is common.
- These lateral trenches need to be only slightly wider than the belt.
- Dig the trenches on at least a 2% slope towards the central collection trench. 3-4% slope is better.
- Dig the central collection trench at least 10 cm deeper than the lateral trenches, with a slope of  $\geq 1\%$  down to a sump or to waste.
- The collection trench needs to be only slightly wider than the collection pipe to be used.
- Sprinkle 1-2 cm of washed coarse sand in the bottom of all trenches.
- Obtain a PVC pipe to run in the trench. 50mm DWV (drainage, water, vent) pipe is recommended because it has thicker walls and will withstand traffic. If there won't be any traffic in your situation you could use cheaper, thinner walled stormwater pipe.
- Place the Capiphon™ belt grooves face down in the trenches and insert one end into the PVC pipe.
- Insert and secure the belt into the pipe, and seal with silicone sealant along the smooth side, and at the edges if there any gaps.

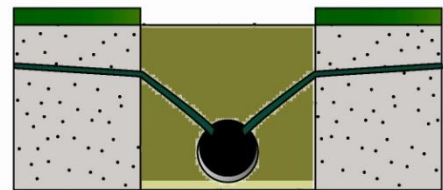
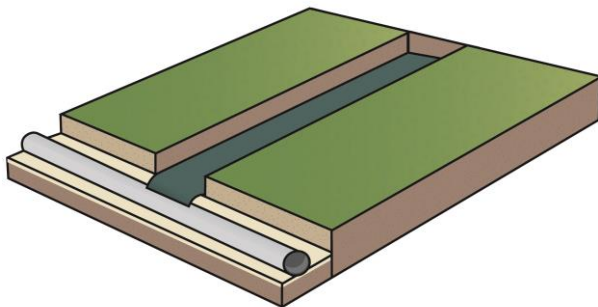
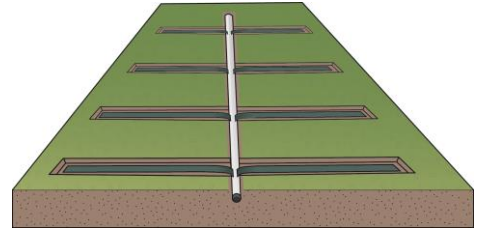

**The power behind this arrangement is that it creates a 10 cm “critical head” for the syphon by dropping the belt into the discharge pipe in a 10 cm trench. This head literally pulls water into the belt along its length and down into the discharge pipe. In doing so it reinforces gravity drainage – simple but powerful.**

# Capiphon™ Drainage Installation Guidelines

## 2. With the belt laid vertically (Intercept or Cut-off Drain)

- Obtain PVC pipe to run in the trench. 50mm DWV (DWV=drainage, water, vent) pipe is recommended because it has thicker walls and will withstand traffic, but if there won't be any traffic in your situation you could use cheaper, thinner walled stormwater pipe.
- Using an angle grinder, cut slots along the top of the pipe at 0.5-2 metre intervals. In general,
  - The higher the clay content the closer the spacing,
  - The higher the risk of damage or inconvenience caused by flooding, the closer the spacing,
  - The higher the rainfall – volume and intensity, the closer the spacing.
- If the drainage area is large, the slotting is best done in a workshop with the angle grinder mounted on a drill press. Any number of lengths of pipe can be joined to give an unlimited length.
- Cut sufficient Capiphon™ belt to run vertically from the bottom of the trench to just below the cultivation depth for each slot.
- Insert and secure the belt into the pipe, and seal with silicone sealant along the smooth side and in any gaps at the sides.
- Dig the trenches down some 20-50 cm below the cultivation depth.
- Dig the trenches on a 0.5-2% slope towards a central sump.
- Spacing between trenches similar or less than normal French Drains.
- The trench needs to be only slightly wider than the collection pipe to be used, say 10 cm.
- No gravel.
- No geotextile.
- Lower the pipe and belt lengths into the bottom of the trench.
- You can then backfill with washed coarse sand or with the spoil if it is reasonably free draining, then seed or lay turf.

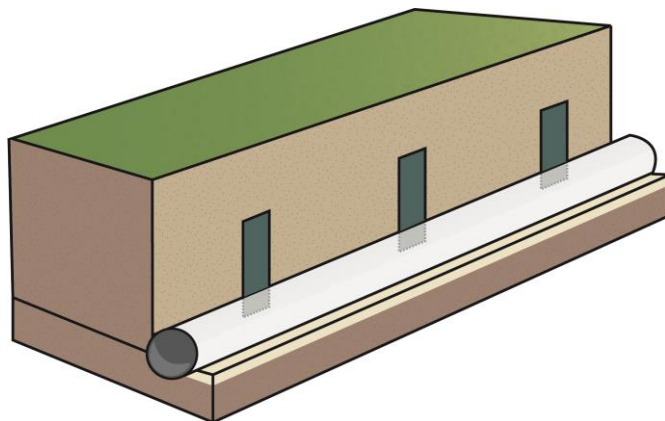

**The power behind this arrangement is that it creates a significant (20-50 cm) “critical head” for the syphon. This head literally pulls water into the belt horizontally from the soil as well as down into the discharge pipe – simple but powerful.**

<sup>5</sup> Capiphon can also be inserted on its edge. This can be useful in tight spaces, especially on the wall of a building or on a property boundary.

# Capiphon™ Drainage Installation Guidelines

## Retaining Walls

### Building new walls

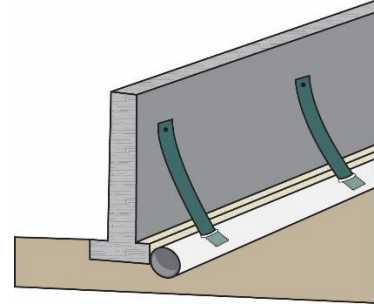
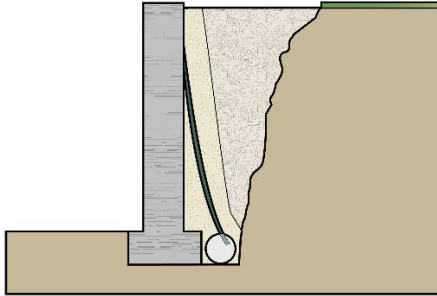

- Obtain PVC pipe to run along the bottom at the rear of the wall. 50mm DWV (DWV=drainage, water, vent) pipe is recommended because it has thicker walls and will withstand heavy loads, but if there if your wall is not more than one metre high and there is no traffic in your situation you could use cheaper, thinner walled stormwater pipe.
- If there is a greater risk of water incursion, a Capiphon Pipe can be used instead of the bare DWV.
- Using an angle grinder, cut slots along the top of the pipe at 0.5-2 metre intervals. In general,
  - The higher the clay content the closer the spacing,
  - The higher the risk of damage or inconvenience caused by flooding, the closer the spacing,
  - The higher the rainfall – volume and intensity, the closer the spacing.
- If the drainage area is large, the slotting is best done in a workshop with the angle grinder mounted on a drill press. Any number of lengths of pipe can be joined.
- Cut sufficient Capiphon™ belt to run up vertically from the bottom of the trench to just below the cultivation depth for each slot.
- Insert and secure the belt into the pipe, and seal with silicone sealant along the smooth side, and in any gaps at the edges.
- Set PVC outlet pipe on a thin bed of washed coarse sand with a 2% slope towards the sump.
- Nail the tops of alternative lengths of belt to the wall with the grooves facing towards the wall.
- Lay the other lengths of belt against the cut face with the grooves facing down, and fix into place with a tent peg or similar.
- Cover the pipe and belts connections with 10-20cm wide “sandwich” of washed coarse sand to the surface, then backfill with the spoil.



# Capiphon™ Drainage Installation Guidelines

## Remediating Existing Retaining Walls

Relieving hydrostatic pressure from behind retaining walls is really simple with Capiphon™ pipe.

- Drill a hole through the wall as close to the base as possible. Use a portable hand-held post-hole auger for small jobs, or a horizontal drill rig for larger.
- When the wall has been breached, continue drill for a sufficient length depending on circumstances.
- Remove the drill from the casing, and insert Capiphon™ pipe, making sure that the end of the pipe is capped.
- Withdraw the casing and allow the soil/rock to collapse to come into contact with the Capiphon™ pipe.



## Under Slabs

Laying Capiphon™ under a concrete slab is an easy way to cope with rising watertable, especially if the slab is to be laid on a cut and fill.

- Dig a trench through the centre of the slab – sometimes coincident with other services – at least 20 cm deep and on 1-2% slope.
- Plan to lay Capiphon™ belt in the usual herring bone pattern. Lateral trenches are not necessary provided that the soil is scraped to provide a 2% slope towards the central trench.
- Sprinkle 1-2 cm of washed coarse sand in the bottom of the trench and under where the belt will be placed. If the area is muddy or is clay, sprinkle 1-2 cm sand across the entire slab area.
- Obtain a PVC pipe to run in the trench. As there won't be any traffic in your situation you can use cheaper, thinner walled stormwater pipe.
- Using an angle grinder cut slots along the top of the pipe
- If the drainage area is large, the slotting is best done in a workshop with the angle grinder mounted on a drill press.
- Space the belts 1-2 metres apart, depending on the expected challenge.
- Cut sufficient Capiphon™ belt to run the length of near the edge of the slab.
- Insert and secure the belt into the pipe, and seal with silicone sealant along the smooth side, and in any gaps at the edges.
- Backfill the trench with washed coarse sand before covering with vapour membrane and pouring the slab as normal.

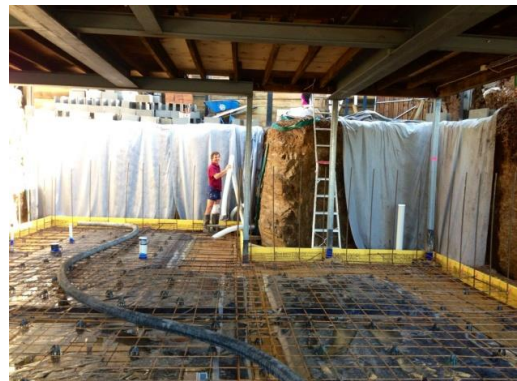

# Capiphon™ Drainage Installation Guidelines

## Inserting Capiphon™ into the Collection Pipe

- Obtain a PVC pipe to run in the trench. 50mm DWV (Drainage, Water, Vent) pipe is recommended because it has thicker walls and will withstand traffic, but if there won't be any traffic in your situation you could use cheaper, thinner walled stormwater pipe.
- Using an angle grinder cut slots along the top of the pipe at the intersection of the lateral trenches.
- If the drainage area is large, the slotting is best done in a workshop with the angle grinder mounted on a jig.
- Cut sufficient Capiphon™ belt to run the length and/or depth required.
- Poke the strips of belt into the slots until they go in as far as they can.
- Secure the belts with 1-2 cable ties as in the diagram. This important to hold the belt in place while positioning the belt/pipe and backfilling.

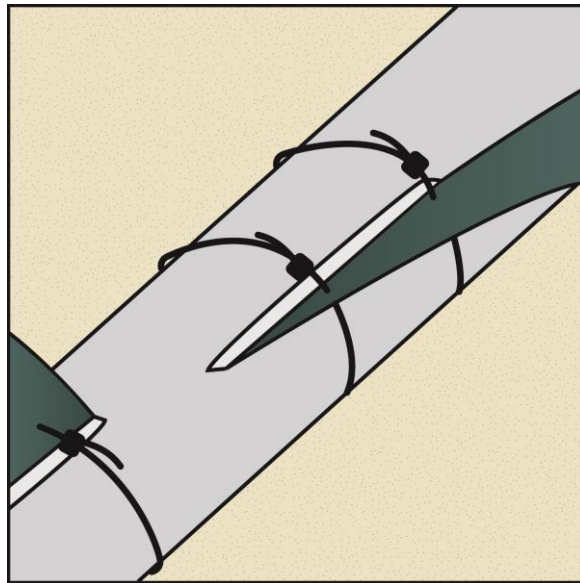

- Run some silicon sealant along the back (smooth side) of the belt and at the sides of the slot if there are any gaps. This is to prevent any particles getting into the collector pipe. Be careful not to put the sealant on the grooved side.
- Make sure that you have an end cap on your collection pipe, and then put it into the trench on a 0.5-2% slope.
- Join as many lengths of PVC pipe as necessary to drain the entire area.
- Lay the lengths of Capiphon™ belt out along the lateral trenches, grooves facing down, and sprinkle a thin layer of washed coarse sand (1-5cm) over them where they lie. Depending on the temperature, the belts may be a bit stiff to handle, so place a brick on the end of them to hold them in place until you have placed the soil on top.
- Run a bead of sealant along the grooves at the free end of the belt. This prevents air getting into the belt and facilitates the syphon effect of pulling water into the belt.
- You can then place the sand/soil over the belts and pipe, before seeding or laying turf, or pouring concrete.

# Capiphon™ Drainage Installation Guidelines

## Fabricating Capiphon™ Pipe

- Obtain 6m lengths of 50mm, 40mm or 25mm DWV PVC pipe and cut to the required length.
- Obtain the Capiphon Belt, purchased as a 6m roll of 175mm, 135mm or 100mm respectively, and cut to the required length.
- In a clean, dry place such as a workshop or new floor, place the pipe the belt flat laid flat, smooth side up.
- Starting at one end, roll the belt around the pipe and secure with rubber bands.
- Make sure that one end of the belt is about 1mm from the end of the pipe. This is the “down” end of the pipe that will go into the collector/connector.
- Continue to wrap the belt along its entire length securing with cable ties.
- If going for the “belt and braces” approach using strips of belt vertically down into the Capiphon Pipe, cut slots along the top of the pipe in the gap between the two sides of the belt (almost) touch.
- Alternatively, cut the slots beforehand, and then wrap the belt to meet up with the slots.
- If the drainage area is large, the slotting is best done in a workshop with the angle grinder mounted on a jig.
- Run silicon sealant along the edge of the belt at the “up” end of the pipe to increase the syphoning effect.
- Make sure that you have an end cap on your collection pipe, and then put it into the trench on a 1% slope.
- Join as many lengths of PVC pipe as necessary to drain the entire area.

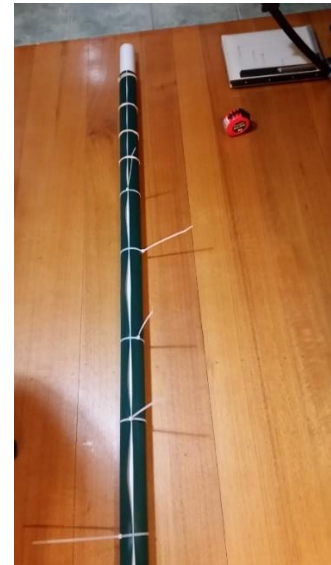

## A Note on Measurements

The measurements used in these Guidelines are approximate. The two most important measurement, though, are the minimum 10mm head and the 2% slope when using the Capiphon Belt laid flat. Water will flow in the grooves only when either the head is greater than 10mm or the slope is 2% or more.

## What Sand to Use?

See separate sheet [WHAT SAND TO USE? - A Simple Permeability Test](#)